



Nidec-Avtron Makes the Most Reliable Encoders in the World

8901 E. PLEASANT VALLEY ROAD • INDEPENDENCE, OHIO 44131-5508
TELEPHONE: (1) 216-642-1230 • **FAX:** (1) 216-642-6037
E-MAIL: tachs@nidec-avtron.com • **WEB:** www.avtronencoders.com

Encoder Instructions

MODEL AV30

SOLID SHAFT

DESCRIPTION

The Avtron Model AV30 is a severe duty absolute encoder. It expresses the position of rotation as an output message or value. AV30 can measure a single turn of rotation or multiple rotations. The AV30 measures the shaft rotation and position without the need for external power or internal batteries through it's innovative Wiegend wire energy system. The AV30 operates down to zero speed and can be used for both control and instrumentation applications.

CAUTION

Do not utilize AV30 in hazardous locations which require ATEX, UL, CUL, CSA, or other explosion protection certification. AV30 is not certified for hazardous locations.

The AV30 is designed for mounting on flanges (58mm, 85mm flanges, or US 1.25"), or on a foot mount bracket for coupling. The AV30 is not recommended for pulley or chain drive applications.

The AV30 housing features non-contacting labyrinth seals. It can withstand rough environments, shock, and vibration in any orientation.

The AV30 utilizes magnetic sensors. This proven technology is ideal for rugged environments since it is immune to many contaminants that cause optical encoders to fail.

SAFETY

The AV30 is not considered as a safety device and is not suitable for connection into a safety system.

WARNING

Installation should be performed only by qualified personnel. Safety precautions must be taken to ensure machinery cannot rotate and all sources of power are removed during installation.

INSTALLATION

Refer to the back page of these instructions for outline and mounting dimensions.

Equipment needed for installation

Supplied:

AV30 Encoder

Optional:

(none)

Not Supplied:

Open Wrenches
 Hex Wrenches
 Dial Indicator Gauge
 Caliper Gauge

The encoder must be driven by a positive drive rather than a friction drive. The following means of coupling are acceptable when properly installed: Direct Coupling.

With a direct drive, use a flexible disc coupling and align the shafts as accurately as possible. For motors with a pre-aligned flange, it is also acceptable to use a "spider" or "jaw" coupling type. If a rubber slinger disc is used, position it on the shaft so it will rotate freely.

Model	Bus	Flange	Shaft	Turns	CPR	Conn	Conn exit	Coding	Add'l drill pattern	Mods
AV30	A- Analog C- CANOpen D- DeviceNet P- Profibus DP S- SSI	1- 58mm flange, 36mm male pilot, 3X M3, 3X M4 @ 48mm BC 2- 58mm flange, 50mm male pilot, 3X M3, 3X M4 @ 42mm BC 4- 2.65" Square flange, 1.25 male pilot" 5- 85mm (B10) flange 6X M6 @ 100mm	B- 3/8" solid shaft w/flat C- 10mm solid shaft w/flat H- 11mm dia. Shaft T- 6mm solid shaft, no flat	X- 0/0-single turn A- 16/4 (analog) 2- 4096/12 3- 8192/13 4- 16384/14 5- 32768/15	2- 4096/12 3- 8192/13	C- 3xM12 4/5/5 pin E- M12/8 pin F- M23/12 pin K- 3x cable entry W- Cable, 1m S- Single cable entry	A- side/radial	Digital 1- Binary 2- Gray Analog 3- 0-5V 4- 0-10V 5- 4-20mA 6- 0-20mA	X- No Additional Face Drill Holes	000- none 9xx- special cable length (xx-feet [0.3m])

The AV30 performance and life will be directly affected by the installation. Following this sequence of steps is recommended.

- 1) Clean and inspect motor/driver shaft. Do not use force to assemble coupling onto motor/driver shaft. Any mounting bracket must be secured to a flat, rigid, vibration free steel or aluminum base which can be machined to accept the mounting hardware.
- 2a) For Foot Mounting: Temporarily mount the AV30 to the foot bracket, install the coupling to the AV30 and driver, and verify that the location is suitable for installation.
- 3a) If the AV30 encoder, bracket and coupling are suited to the area, check motor/encoder shaft alignment with a straight edge from multiple positions around the shaft circumference to verify that it meets specifications.
- 4a) While maintaining alignment, precisely mark the position of the foot bracket on its mounting base.
- 5a) Remove the AV30. Transfer punch or layout the mounting hole pattern as indicated on outline drawing.
- 6a) Machine through holes or tap holes in center of base slots to give some degree of freedom in final alignment.
- 7a) Reinstall the AV30 with the flexible coupling loosely in place, and tighten down all mounting hardware. Check motor/encoder shaft alignment with a straight edge from multiple positions around the shaft circumference to verify that it meets specifications. Use thread locker on cap screws which mount AV30 to foot bracket. Proceed to step 8.
- 2b) For Flange Mounting: Temporarily mount the AV30 to the flange bracket, install the coupling to the AV30 and driver, and verify that the location is suitable for installation.
- 3b) If the AV30 encoder, bracket and coupling are suited to the area, check motor/encoder shaft alignment with a straight edge from multiple positions around the shaft circumference to verify that it meets specifications.
- 4b) If the shaft angular alignment is not acceptable, loosen the mounting screws to the flange and apply thin metal shims to the face of the encoder and retest the angular alignment until acceptable.
- 5b) If the shafts are parallel, but misaligned (parallel misalignment), the flange will need to be re-machined. Shimming will NOT correct parallel misalignment, and will lead to premature bearing wear or coupling breakage. (After correcting alignment, proceed to step 8)
- 8) Ensure any flat or keyway on the motor and encoder shaft are aligned with the set screw holes of the flexible coupling. Apply thread locker to coupling set screws and tighten per manufacturer's recommendations.
- 9) Recheck alignment and tighten all hardware after first several hours of operation.

ENVIRONMENTAL CONSIDERATIONS

Follow these steps to reduce potential problems:

- 1) Always mount connection points, conduit couplings, junction boxes, etc., lower than actual encoder.
- 2) For washdown areas, shroud or otherwise cover the encoder to prevent direct water spray. Do not attach the shroud directly to the encoder.

REPAIRS

REMOVAL INSTRUCTIONS:

1. Unfasten coupling.
2. Remove the screws which secure the encoder to the flange or foot mount. Note that the foot mount can remain in place.
3. Slide the encoder free of the mount.

REPLACING PARTS

The AV30 has no user-replaceable parts.

CAUTION

Do not attempt to remove, service, or adjust any of the internal components of the AV30.

WIRING INSTRUCTIONS

CAUTION

Remove power before wiring.

Interconnecting cables specified in the wire selection chart are based on typical applications. Refer to the system drawing for specific cable requirements where applicable.

Physical properties of cable such as abrasion, temperature, tensile strength, solvents, etc., are dictated by the specific application and communications bus. Do not use unshielded cable. Ground one end (only) of the shield to earth ground.

Do not run encoder wiring parallel to power cable wiring for extended distances, and do not wrap encoder cable around power cables.

TROUBLESHOOTING:

If the controller indicates a loss of encoder fault, check the encoder power supply. If power is present, check polarity. If the wiring appears correct and in good shape, test the wiring by replacing the AV30. If the controller still shows encoder loss/fault, then the wiring is faulty and should be repaired or replaced.

An oscilloscope can also be used to verify output of the AV30 encoder at the encoder connector itself and at the drive/ controller cabinet. Depending on the communication method, signals will vary but the oscilloscope should show the output signals varying. Keep in mind that SSI and Profibus DP are master-slave systems and require the controller to signal the encoder to transmit position.

For SSI, monitor the clock input line to ensure the controller is triggering the encoder to send position. The clock should obey the signal requirements shown in the SSI signal section, and should appear as a rapid set of transitions on the clock line. For Profibus DP, CANOpen, and DeviceNet, the transmit and receive signal pairs should change state rapidly as the controller transmits messages to the encoder and the encoder replies. Transmission rates vary, but these messages can be extremely short and typically require scope triggering to spot them.

For Profibus DP, ensure termination resistors are in place (or switched on) at each end of the cabling system, and that no termination resistors are in place in the middle of the system.

For analog output, a multimeter can be used to measure the output signal. Disconnect the encoder outputs to ensure no interference from field wiring and measure the output voltage or current depending on the output style selected. Rotating the shaft should produce a change in output value.

Analog Protocol "A"

Set Lower End Point 1

(input, ACTIVE HIGH, Falling Edge, 10K resistance)

NOTE

When setting the output, both the upper and lower end points must be set for the encoder output to correctly read the minimum and maximum output values.

To set the encoder output to the minimum value, rotate the shaft to the desired position then raise Set Lower End Point 1 > 10V, < Vs for more than 1 second.

**Set Upper End Point 2
(input, ACTIVE HIGH, Falling Edge, 10K resistance)**

To set the encoder output to the maximum value rotate the shaft to the desired position then raise Set Upper End Point 2 > 10V, < Vs for more than 1 second.

(Only) once both the upper and lower end points have been set, the encoder output will correctly move between the minimum and maximum values over the travel range between the lower and upper end points.

For analog output: If the output is within the expected range but does not seem to change, the analog value may have been accidentally scaled to a tiny fraction of a revolution or such a huge number of turns that the output change cannot be detected. Connect both Set End Point 1 and Set End Point 2 to +Vs for 1 second or more, then connect them to ground or no connection. The encoder will be reset to use the full scale factory default with the output and position set to the mid-point of the full scale. Now monitor output voltage or current while rotating. You should observe a voltage or current change. Now follow the instructions in the analog section to properly reset the analog minimum and maximum values.

ELECTRICAL SPECIFICATIONS

- A. Operating Power (Vin = +Vs)
 - 1. Voltage & Current
 - Analog V Out: 12-30VDC; 15mA @ 24V
 - Analog I Out: 15-30VDC; 40mA @ 24V
 - CANOpen: 10-30VDC; 100mA @ 10V, 50mA @24V
 - DeviceNet: TBD
 - J1939: TBD
 - SSI: 5-30VDC; 125mA @ 5VDC, 30mA @ 24V
 - 2. Total Current as above plus cable load
- B. Output Format
 - 1. Analog Voltage 0.5-4.5V; 0-5V; 0.5-9.5V; 0-10V
 - Current 0-20mA or 4-20mA
 - 2. SSI: 100kHz-2mHz, set by master clock speed
 - 3. CANOpen 20kBaud to 1mBaud, node 0-127
 - Default 125k, node 32 (20H)
 - 4. DeviceNet TBD
- C. Direction Counting Default up for CCW rotation as viewed from the back of the encoder
- D. Counts Per Turn 4096 - 8192 (12 - 13 bits)
- E. Maximum Turns 4096 - 32768 (12 - 15 bits)
- F. Line Driver Specs: See table
- G. Connectors: See connector options on page 1
- H. Accuracy: +/-0.35 deg (+/-21 arc-min)
- Analog Linearity: 0.15%

MECHANICAL

- A. Shaft Inertia 0.25lb-in-sec² [295 g-cm² (dyn)]
- B. Acceleration 5000 RPM/Sec. Max
- C. Speed: 5000 RPM Max
- D. Weight: 3 lbs [1.4kg]
- E. Vibration 30 Gs, 5-2000 Hz (any orientation)
- F. Shock 300 Gs 6mSec, any orientation
- G. Shaft Load 50lbs Radial (225N) Max
- 65lbs Axial (290N) Max

ENVIRONMENTAL

Solid cast aluminum housing
 Operating Temperature: -40°C to +85°C.
 Finish Polyurethane enamel, 2 layer
 Resists mild acids, bases, salt water & hydrocarbons

LINE DRIVER OPTIONS

Electrical Specifications		BUS OPTIONS						Units
		Analog	CANOpen	DeviceNet	J1939	Profibus	SSI	
Input Voltage		12-30V	10-30V	TBD	10-30V	TBD	10-30V	VDC
Line Driver		NA	TBD	TBD	TBD	TBD	MAX3294	
Cable Drive Capacity		NA	TBD	TBD	TBD	TBD	4000' [1200m]*	feet
Protection	Reverse Voltage	yes	yes	TBD	TBD	TBD	yes	
	Short Circuit	yes	yes	TBD	TBD	TBD	yes	
	Transient	yes	yes	TBD	TBD	TBD	yes	

* @100kbaud w/24 AWG, 52.5 pF/meter (16 pF/foot)

SSI Protocol “S”

The SSI Protocol “S” provides a clocked set of data bits that represent the encoder position (in turns and within 1 turn). Each bit is output by the encoder as the clock input transitions.

Preferred cable: Twisted pair with individual and overall shield grounded at one end only. 24 AWG, copper conductor, capacitance of 52.5 pF/meter (16 pF/foot) terminated in a 100 Ohm resistive load. Note that resistive losses in long cables may decrease actual voltage (+Vs) available at the encoder; larger conductors can be used or the encoder can be powered locally and signal GND brought through the cable. Maximum transmission speed is limited by cable length as shown in the figure below.

For more details on SSI, consult Wikipedia:

http://en.wikipedia.org/wiki/Synchronous_Serial_Interface

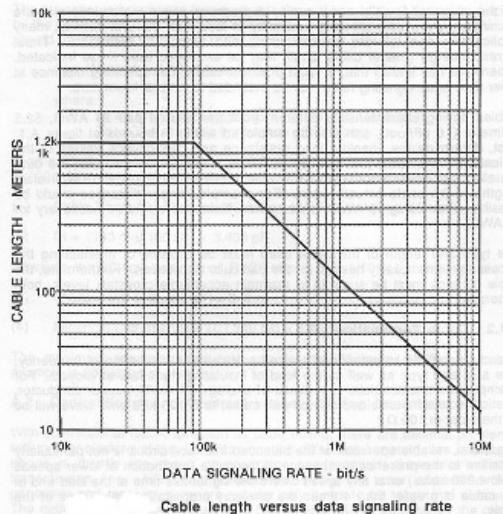
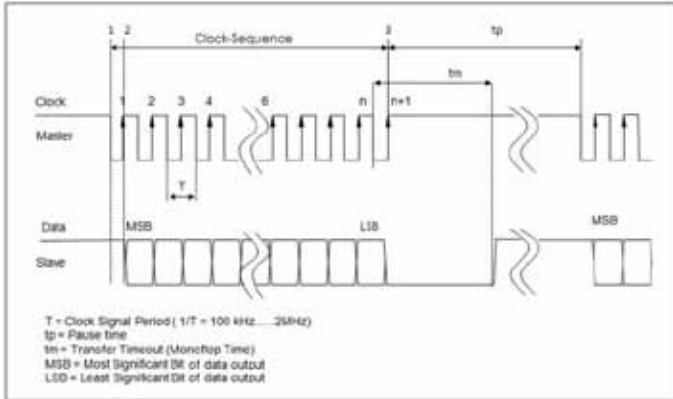

Set Zero (input, ACTIVE HIGH, Falling Edge, 10K resistance)

To set the encoder count value to zero, raise Set Zero > 10V, < Vs for more than 1 second. Upon the Set Zero signal returning to logic zero (falling edge), the encoder count value will be set to zero.

Set Direction (input, 10K resistance)

For input logic zero or no connection, the encoder will count UP for CCW rotation as viewed from the rear end of the encoder.

For input logic 1 (>10V, <Vs), the encoder will count DOWN for CCW rotation as viewed from the rear of the encoder.

Analog Protocol “A”

The analog protocol provides a steady-state analog output which represents the encoder position., over a portion of a turn, or any portion of a turn plus a number of turns. The factory default is 0-16 turns = min/max output. This can be modified by using the Set Lower and Set Upper End Point inputs similar to most electronic cam-setting systems (described below.)

Preferred cable: Overall shield grounded at one end only. Twisted pair cable acceptable but not required. Note that resistive losses in long cables may decrease actual voltage (+Vs) available at the encoder; larger conductors can be used or the encoder can be powered locally and signal GND brought through the cable.

Output	0-5V	0-10V	0.5-4.5V	0.5-9.5V	4-20mA	0-20mA	Units
Signal Code	“3”	“4”	“7”	“8”	“5”	“6”	
Min. Supply Voltage	12V	12V	12V	12V	15V	15V	Vdc
Min. Load	10k	10k	10k	10k	0	0	ohms
Max. Load	Any	Any	Any	Any	500	500	ohms
Settle Time	80mS						mS
Min. Travel Turns	0.06 turns /22.5 deg.						Turns/Deg.
Max. Travel Turns	65536 turns						Turns

Set Lower End Point 1 (input, ACTIVE HIGH, Falling Edge, 10K resistance)

To set the encoder output to the minimum value at the present position of rotation, raise Set Lower End Point 1 > 10V, < Vs for more than 1 second. Upon the Set Lower End Point 1 signal returning to logic zero (falling edge), the encoder output will be set to the minimum output shown in the output table.

Set Upper End Point 2 (input, ACTIVE HIGH, Falling Edge, 10K resistance)

To set the encoder output to the maximum value at the present position of rotation, raise Set Upper End Point 2 > 10V, < Vs for more than 1 second. Upon the Set Upper End Point 2 signal returning to logic zero (falling edge), the encoder output will be set to the maximum output shown in the output table.

Reset Upper and Lower End Points to Factory Default (16 turn scaling)

Raise both Set Lower End Point 1 and Set Upper End Point 2 > 10V, < Vs for more than 1 second. Upon both signals returning to logic zero, the encoder output will be reset to the factory default scaling of maximum output over 16 turns (only applies to the MT option, and the present position and the encoder will be set to the mid-point (8 turns) and 1/2 of the maximum output.

AV30 WIRING DIAGRAMS

Communication Bus "A": Analog Pinout

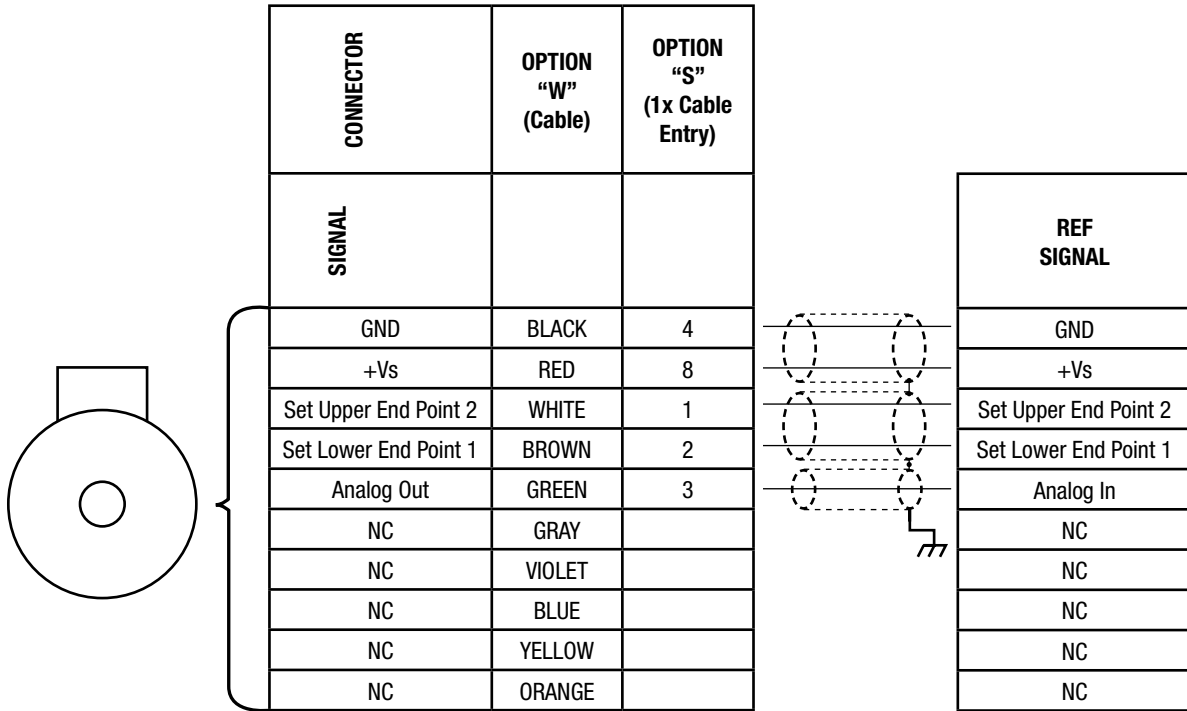

* Note: Overall shield required; twisted pair cable not required, pairs shown only for convenience

Communication Bus "S": SSI Pinout

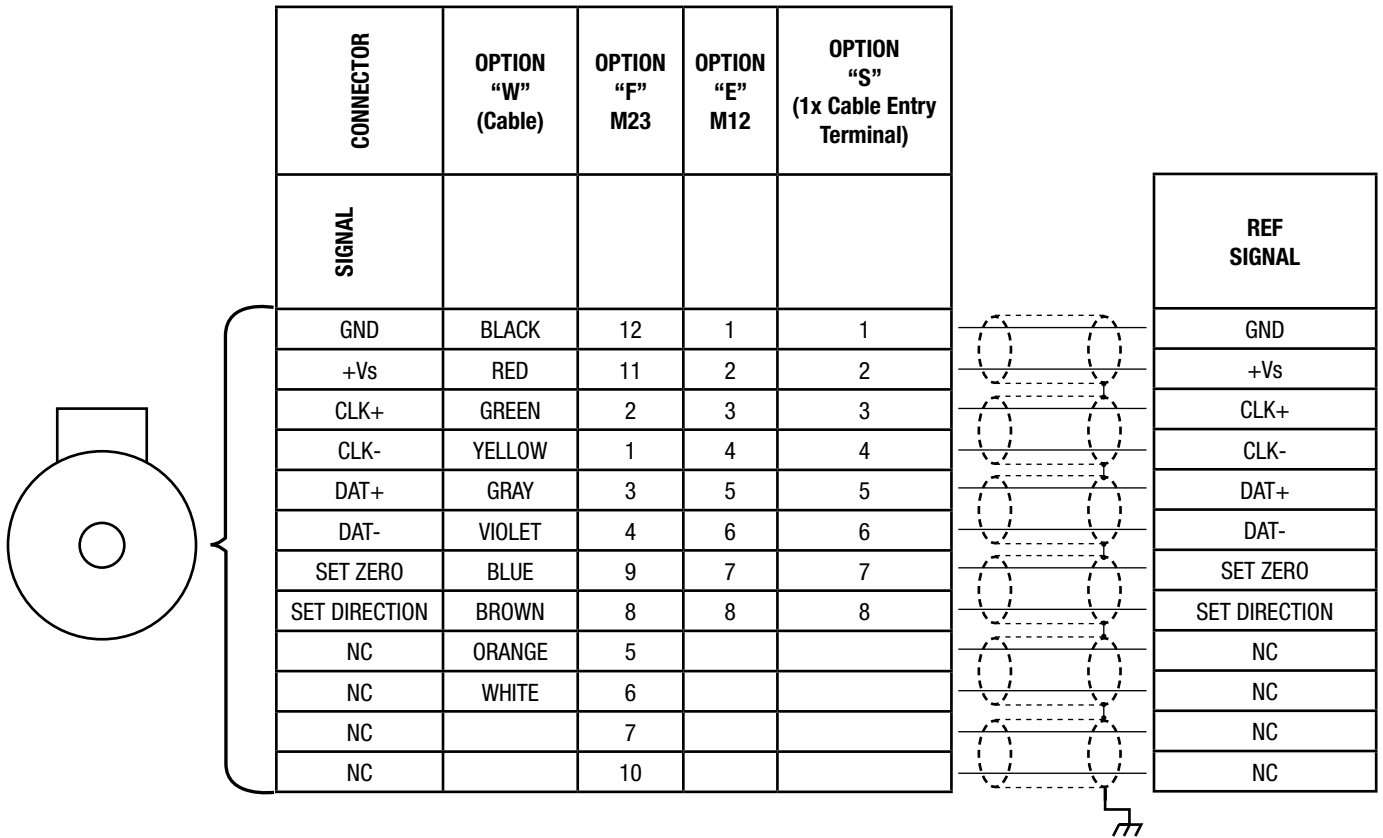

* NOTE: Twisted pair cable required with overall shield; individual pair shielding recommended. Obey pairing as shown

AV30 OUTLINE DRAWINGS

FLANGE OPTION "1", SHAFT OPTION "C"

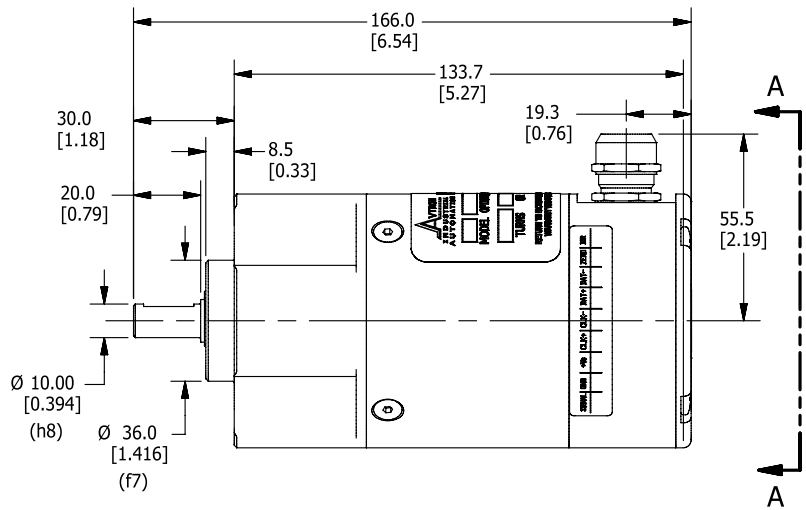
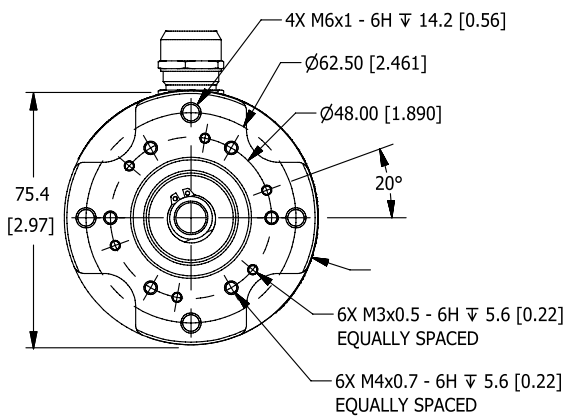

OPTIONS SHOWN ON THIS SHEET

SHAFT: 10MM "C"

PILOT: 36MM "1"

CONNECTOR: CORD GRIP "S"

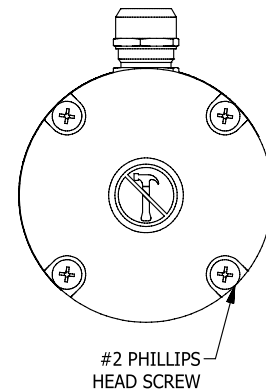

DIMENSIONS IN mm [INCH]

AV30 OUTLINE DRAWINGS (Cont'd)
FLANGE OPTION "2", SHAFT OPTION "T"

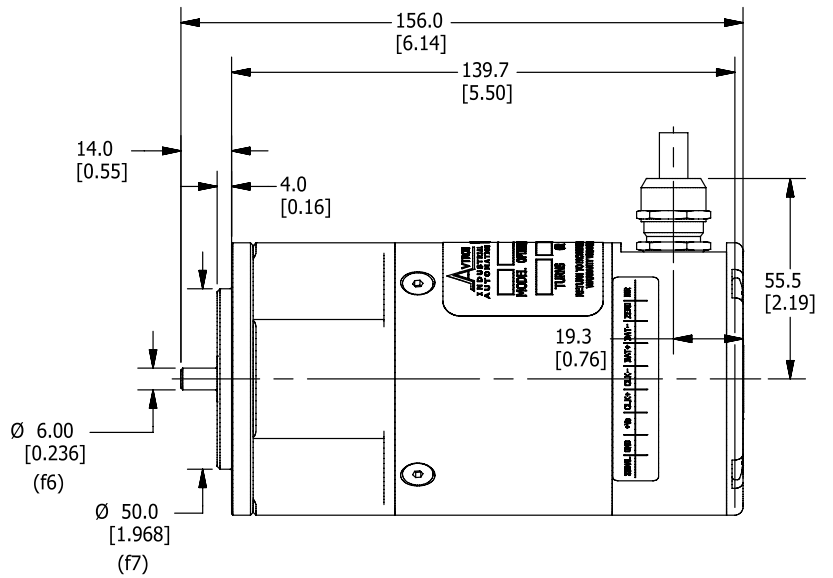
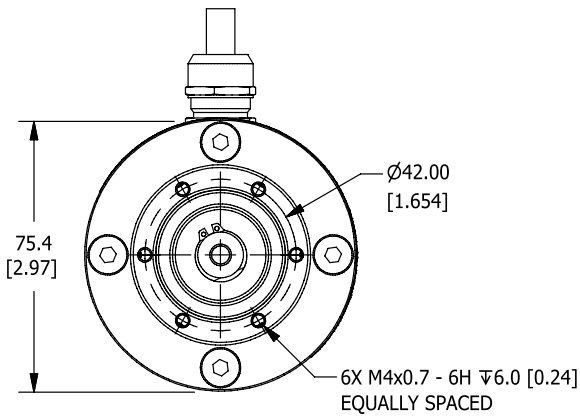

OPTIONS SHOWN ON THIS SHEET

SHAFT: 6MM "T"

PILOT: 50MM "2"

CONNECTOR: CORD GRIP WITH 1M CABLE "W"

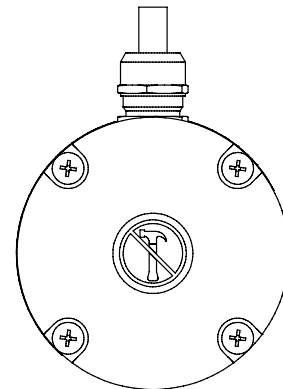

DIMENSIONS IN mm [INCH]

AV30 OUTLINE DRAWINGS (Cont'd)
FLANGE OPTION "4", SHAFT OPTION "B"

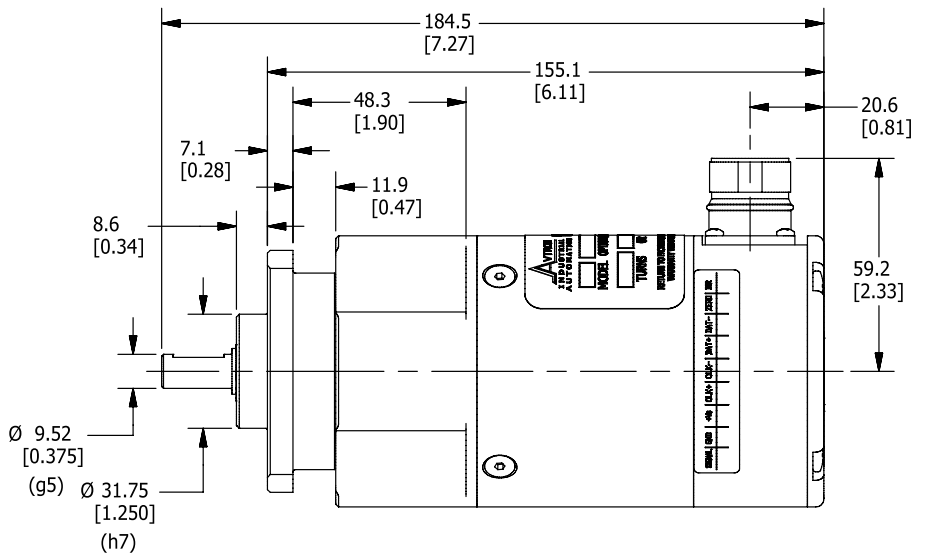
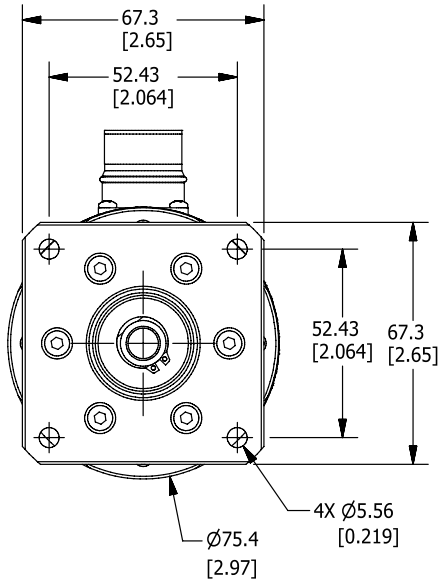

OPTIONS SHOWN ON THIS SHEET

SHAFT: 0.375 IN. "B" (ONLY AVAILABLE WITH 1.25 PILOT)

PILOT: 1.25 IN. "4"

CONNECTOR: M23 "F"

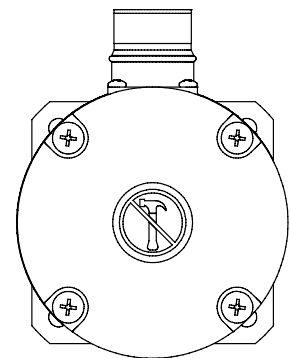

DIMENSIONS IN mm [INCH]

AV30 OUTLINE DRAWINGS (Cont'd)

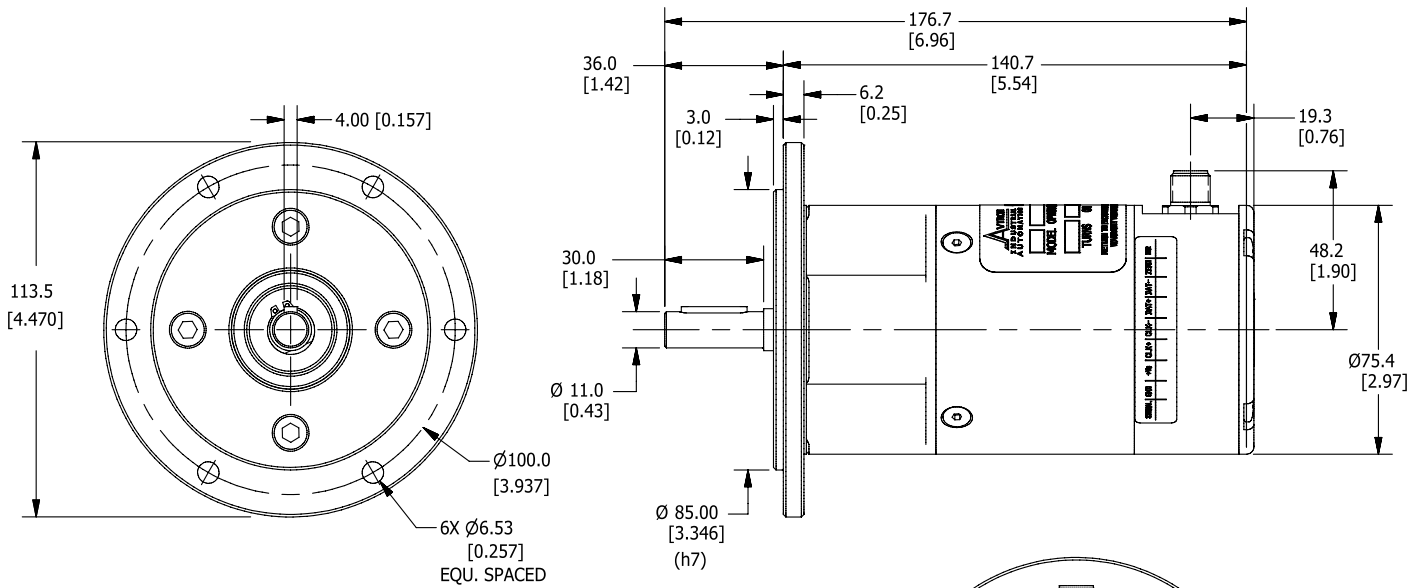
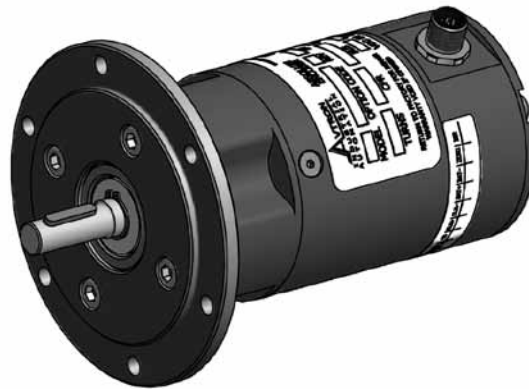

OPTIONS SHOWN ON THIS SHEET
SHAFT: 11MM WITH KEY "H"
PILOT: 85MM "5"
CONNECTOR: M12 "E"

DIMENSIONS IN mm [INCH]



Nidec-Avtron Makes the Most Reliable Encoders in the World
 8901 E. PLEASANT VALLEY ROAD • INDEPENDENCE, OHIO 44131-5508
 TELEPHONE: (1) 216-642-1230 • FAX: (1) 216-642-6037
 E-MAIL: tachs@nidec-avtron.com • WEB: www.avtronencoders.com

REV: 08/22/16