

## ENCODER INSTRUCTIONS

## HS35X

### Hollow Shaft Magnetic Incremental Encoder

### DESCRIPTION

The Avtron Model HS35X Hollow Shaft Rotary Incremental Encoder is a speed and position incremental transducer (also known as tachometer or rotary pulse generator). When mounted to a motor or machine, its output is directly proportional to shaft position (pulse count) or speed (pulse rate). The HS35X operates down to zero speed and can be used for both control and instrumentation applications.

The HS35X employs a hollow shaft and clamping collar to secure the encoder to the shaft. Ceramic bearings plus an optional high-performance resin hollow shaft insert provide electrical isolation from motor shaft currents and permits models to fit a broad range of shaft sizes from 1/2" to 1" [12mm - 25mm] by adapting the native 1" or 25mm bore size.

An anti-rotation bracket prevents rotation of the encoder while allowing for shaft end float and axial movement. An optional protective basket kit offers additional protection from impact and motor lifting damage. The HS35X encoder offers 2Ø outputs (A,B) 90° apart for direction sensing (A Quad B), with complements (/A,/B) and with marker pulse and complement (Z,/Z)

### INSTALLATION CONSIDERATIONS

See page 3 and drawing on page 7 for shaft engagement rules. The motor shaft may include a keyway, but the key must be removed prior to installation as the HS35X does not support the use of a key.

The HS35X offers optional Avtron flexible anti-rotation tethers/brackets which will permit the encoder to tolerate ±0.1" of shaft end float/axial movement. Select the proper tether for the application from the table below.

#### CAUTION:

**Be careful not to damage the clamping fingers of the hollow shaft during handling. Do not tighten clamping collar before installation onto motor shaft.**

#### WARNING:

**Installation should be performed only by qualified personnel. Safety precautions must be taken to ensure machinery cannot rotate and all sources of power are removed during installation.**

#### WARNING:

**Be certain to identify thread locker and anti-seize compound correctly. Using anti-seize in place of thread locker can cause mechanical failure leading to equipment failure, damage, and harm to operators.**

HS35X PART NUMBERS AND AVAILABLE OPTIONS

Model	Output PPR	Line Driver	Bore Size	Connector Options	Shaft Style	Protection	Tether Options	Channels	Special Features
HS35X	M- 250 N- 256 Q- 500 R- 512 W- 1000 Y- 1024 C- 1500 3- 2000 4- 2048 5- 2500 T- 3072 D- 4096 9- 5000 2- 8192 1- 10000	1- 6-30V in / out 2- 6-30V in / 5V out 3- 5V in / 5V out	USA/SAE B- 1/2" C- 5/8" D- 3/4" E- 7/8" F- 1" (Native Bore) U- Universal SAE 1/2"-7/8" via inserts (Native 1" bore)  METRIC P- 12mm Q- 14mm R- 15mm S- 16mm V- 19mm W- 20mm Y- 25mm (Native Bore) Z- Universal Metric 12-20mm via inserts (Native 1" Bore)	A- 10 PIN MS, W/O Plug, Standard Phasing B- 10 PIN MS, W/O Plug, Reverse Phasing C- 10 PIN MS, W/ Plug, Standard Phasing D- 10 PIN MS, W/ Plug, Reverse Phasing W- M20 Cord Grip W/ 18" Cable Y- M20 Cord Grip W/ 18" Cable (BEI Wire Colors)	U- Universal thru shaft X- Thru shaft no cover	0- None 1- Basket	X- None A- Fan Cover 1/4-20 B- Fan Cover 5/16-18 C- Fan Cover 3/8-16 D- Fan Covers (A+B+C) E- 4.500 C-Face F- 8.500 C-Face M- D + E U- D + E + F R- Block & Pin (BEI STYLE)	A- All Channels	000- None 4xx- Special PPR (See Table) 9xx- Special Cable Length xx=Feet 090- IP66 Rated Sealing

## INSTALLATION

Refer to the back page of these instructions for outline and mounting dimensions. Also available: EU (European Union) Installation Sheet and Basket Mount Installation Sheet.

INCLUDES	OPTIONAL	NOT INCLUDED
<ul style="list-style-type: none"><li>• HS35X Encoder w/ Clamping Collar</li><li>• Thread Locker (Blue)</li></ul>	<ul style="list-style-type: none"><li>• Tether Bracket</li><li>• Anti-Rotation Arm</li><li>• Grounding Strip</li></ul>	<ul style="list-style-type: none"><li>• Caliper Gauge</li><li>• Dial Indicator Gauge</li><li>• Torque Wrench</li></ul>

- 1) Disconnect power from equipment and encoder cable.
- 2) Use caliper gauge to verify motor shaft is proper diameter and within allowable tolerances: +0.000", -0.0005" [+0.00, -0.013mm].
- 3) Clean machine shaft of any dirt and remove any burrs.
- 4) Use dial indicator gauge to verify the motor shaft Total Indicated Runout (TIR) < 0.002" [0.05mm].
- 5) Install the anti-rotation bracket to the face of the encoder using 8-32 screws and lock washers.
- 6) Loosen clamping collar and insert shaft sizing insert into encoder. DO NOT FORCE. The insert has a retaining flange and is larger at one end than the other.
- 7) Test Fitting: carefully slide the encoder onto the shaft to verify fit. Ensure a minimum of 1/8" [3mm] between encoder and mounting surface. DO NOT FORCE. Encoder should slide on easily. If the encoder does not fit easily, remove it, verify shaft size and check for burrs and shaft damage.
- 8) Tighten screws on clamping collar evenly until snug. Then tighten each screw to 45-50 in-lbs [5.1-5.6 N-m]. DO NOT USE A STANDARD RIGHT ANGLE WRENCH. Use only a torque wrench with hex bit (recommended) or a T-handle hex wrench.
- 9) Secure free end of anti-rotation bracket to motor frame. Use insulating hardware as shown (supplied with Avtron anti-rotation kit). Use additional washers as needed to install the bracket without deflection or bend to avoid stress.
- 10) Turn shaft by hand and verify the shaft turns freely and does not produce excessive runout/wobble of the encoder: <0.005" [0.13mm] runout. Additional instructions under "Adjusting the Encoder to Eliminate Excess Runout/Wobble" are provided if needed.
- 11) Connect cable as shown in wiring diagram.
- 12) Apply power to the encoder.
- 13) Rotate the shaft by hand, or using jog mode of the speed controller and verify proper direction.
- 14) Optional: Install Protective Basket using either T-bolts (Fan Cover) or bolt to 4.5" C-Face (bolts provided). For 8.5" C-Face use adapter clips supplied. Be certain that the Protective Basket does not touch or interfere with the anti-rotation arm. To mount the basket on an 8.5" C-face, thread the 1/2"-13 bolts into the motor face, through each clip (provided with options "F" and "U") but do not tighten fully. Pivot the basket over the encoder, and pivot each clip over each respective basket bolt hole. DO NOT FORCE. Tighten each bolt to secure the basket and clip. NOTE: Order part #: A32920 for protective basket guard and all tethers

## WIRING INSTRUCTIONS

- 1a) For units with factory-installed connector(s) (MS 10-pin) connector cable as shown in wiring diagram
- 1b) For units with factory-installed cable, terminate as required per local installation.
- 1c) For unwired units:
  - 1c-i) Strip cable and wires per illustration
  - 1c-ii) Remove the sealing nut, claw, and seal from the cable gland and pass cable through the nut, claw, and seal in the order in which they were assembled on the encoder housing.

- 1c-iii) Slide seal inside claw and pass wires through the cable gland.
- 1c-iv) Slide seal inside claw and pass wires through cable gland.
- 1c-v) Re-tighten sealing nut onto cable gland.

### CAUTION:

**Be sure to remove power before wiring the HS35X encoder. Be sure to ground the cable shield(s): It can be connected to case ground at the receiving device ONLY. (The standard anti-rotation arm kits provide insulating washers to prevent encoder connection to ground)**

The HS35X encoder can be wired for single phase or two-phase operation, either with or without complements, with or without markers. See connector options and wiring diagrams.

### CAUTION:

**When wiring for differential applications (A,/A,B,/B,Z,/Z), A and /A should be wired using one twisted, shielded pair; B and /B should be in a second pair, etc. Failure to use complementary pairs (say, using A and B in a twisted pair) will reduce noise immunity significantly.**

For encoder output that correctly reflects the direction of rotation, proper phasing of the two output channels is important. Phase A channel leads phase B channel for clockwise shaft rotation as viewed from the back (non-mounting side) of the encoder for standard phasing options ("A", "C", & "W"). Follow instructions under corrective installation as needed to reverse the direction of output or purchase HS35X with reverse (Dynapar HS35) phasing (options "B", "D").

### Adjusting the Encoder to Eliminate Excess Runout/Wobble:

In a typical installation an encoder housing movement of 0.005" runout or less (as measured at the outside diameter of the main encoder body) will not have an adverse effect. If excessive housing movement is detected in the installation:

- 1) Check the shaft the HS35X is mounted on for excessive shaft runout using a dial gauge. NEMA MG1 calls for 0.002" TIR or less.
- 2) Verify that the mounting shaft meets minimum and maximum diameter tolerances.
- 3) Maximize the shaft insertion into the encoder (retaining the minimum of 1/8" between mounting face and encoder)
- 4) Loosen the clamping collar and rotate the motor shaft 180° within the encoder hollow shaft sleeve. Retighten the clamping collar.
- 5) Loosen the clamping collar; move the split in the clamping collar over a solid portion of the encoder shaft, retighten the clamping collar.

If excessive housing movement still exists after the above steps, the shaft or the encoder may be damaged and should be checked by the manufacturer.

### Shaft Sizes:

HS35X: 1/2", 5/8", 3/4", 7/8", 1" native, 12mm, 15mm, 16mm, 20mm, 25mm native

### NOTE:

**HS35X units <1"/25mm bores utilize shaft insulating resin insert; models may be resized as needed by interchanging or removing inserts. Consult factory for other shaft sizes not shown.**

### Shaft Engagement:

HS35X: Shaft insertion/engagement should be 1.25" to 2.25" [32mm to 57mm] with a minimum of 0.125" [3mm] between encoder and motor mounting face. Minimum insertion/engagement is 1.75" [44mm] for models using a sizing insert.

## CORRECTIVE ACTION FOR PHASE REVERSAL

If Encoder Direction is Reversed:

- 1) Remove power.
- 2) Exchange wires on cable, either at encoder cable end, or at speed controller end (but not both):
  - a.) Single Ended 2 Phase Wiring (see wiring diagram below) Exchange A and B at the user end of the wires.
  - b.) Differential 2 Phase Wiring (see wiring diagram below) Exchange either A with /A in the phase A pair OR B with /B in the phase B pair but NOT both.
- 3) Apply power.
- 4) Verify encoder feedback is correct, using hand rotation of shaft, or jog mode of the speed controller.

## CABLE

For maximum performance, use Avtron ultra-low capacitance cable, CBL1BBA18PWyyy.y, where yyy.y is the cable length in meters.

Interconnecting cables specified in the wire selection chart are based on typical applications. Refer to the "Wiring Diagrams" below for suggested cable types. General electrical requirements are: stranded copper, 22 thru 16 gauge, each wire pair individually shielded with braid or foil with drain wire.

Maximum cable length (and line driver selection) is limited by several factors: line driver selection, maximum RPM, PPR, output voltage and cable capacitance. Line driver option "2" permits the longest cable lengths (up to 300m at 45KHz). All HS35X line drivers have full protection against external faults. These factors may dictate maximum potential cable lengths.

## FAULT-CHECK

After power-up and the rotor position is checked by the sensor, the Fault-Check LED will turn GREEN.

If the adaptive electronics reach their adjustment limit for any reason, the Fault-Check alarm and LED will notify the drive and operator of an impending failure. The LED will turn RED if the Adaptive Electronics reach their adjustment limit. This output occurs before an actual failure, allowing steps to be taken to replace the unit before it causes unscheduled downtime. Fault-Check annunciation is available as an "alarm" output through the connector and as an integral LED.

## TROUBLESHOOTING

### If the drive indicates a loss of encoder/tach fault and the HS35X fault check LED is OFF:

Check the encoder power supply. If power is present, check polarity; one indicator of reversed power supply is that all outputs will be high at the same time (~+=+V).

### If the drive indicates encoder fault, but the LED shows GREEN:

Check the wiring between the drive and the encoder. If the wiring appears correct and in good shape, test the wiring by replacing the HS35X. If the new unit shows GREEN, and the drive still shows encoder loss/tach fault, then the wiring is faulty and should be repaired or replaced.

### If the alarm output and/or LED indicate a fault (RED) at power-up or while running:

Replace the HS35X. If the replacement unit also shows RED, check for magnetic interference. An oscilloscope can also be used to verify proper output of the encoder at the encoder connector itself and at the drive/controller cabinet. If the outputs show large variations in the signals at steady speed (jitter or "accordion effect", see figure 5), the motor or shaft may be highly magnetized. Replace any magnetized material nearby with non-magnetic material (aluminum, stainless) (especially shafts). For GE CD frame motors and similar styles, Avtron offers non-magnetic stub shafts.

### If the alarm output and/or LED indicate an output fault (ORANGE/blinking ORANGE):

This indicates that the outputs have shut off due to the thermal overload. The usual cause for overloaded outputs is some combination of high signal frequency (AC load), high temperature, long cable length, high voltage, and/or DC load. Excessive DC load can be related to how the cables are terminated at the drive end, but can also be indicative of short circuit(s).

If equipped with the remote alarm option (Mod code 068), the /ALM output will be asserted Low (~OV) whenever the LED is either RED or ORANGE.

If the LED is OFF, but power is being applied to the encoder, check the output voltage level at A<sub>i</sub>/A<sub>B</sub>, B<sub>i</sub>/B<sub>B</sub>. If all outputs are Low (~OV), the connections to +V and COM are reversed. Swap connections between +V and COM; the LED should turn GREEN.

## WIRING DIAGRAM / PINOUT

CONNECTOR	CONNECTOR "W" (CABLE)	OPTION "Y" (CABLE-BEI PINOUT)	OPTION "A", "B", "C", "D" (10- PIN MS)	REF SIGNAL
Encoder Wiring	Green	Yellow	A	A
	Yellow	White/Yellow	H	/A
	Blue	Blue	B	B
	Gray	White/Blue	I	/B
	Orange	Orange	C	Z
	White	White/Orange	J	/Z
	Violet	N/C	N/C	/ALM*
	Red	Red	D	+Vin
	Black	Black	F	GND

\*Remote alarm output available by selecting 068 mod code

All Connector Options except B and D have Standard Phasing, A Leads B for CW rotation, viewed from encoder side of motor.

Note for Connector Option B and D with Reverse Phasing, the Phasing is inverted via Configuration; the Wiring and Pinout is the same as for Standard Phasing (Connector option A and C). For Connector Option B and D with Reverse Phasing, B Leads A for CW rotation, viewed from encoder side of motor.

(see sketch below for Phasing Point of View)

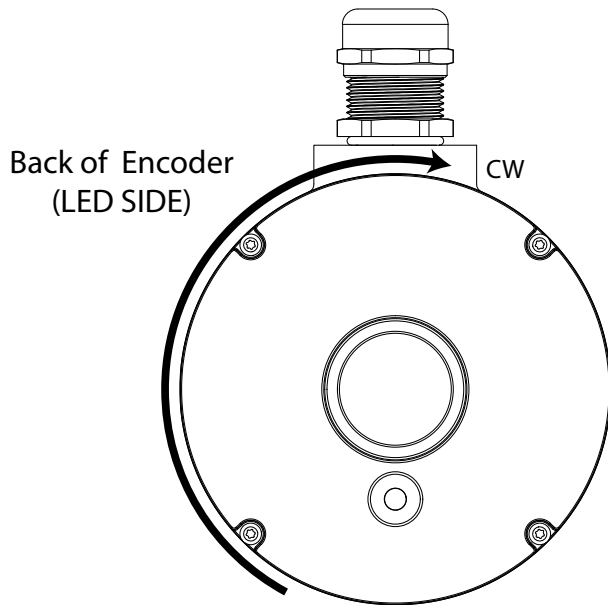

Standard Phasing: A Leads B for CW Rotation (viewed from back of encoder)



Reverse Phasing: B Leads A for CW Rotation (viewed from back of encoder)

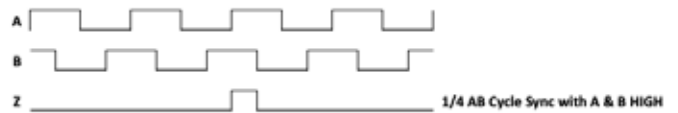

## SPECIFICATIONS TABLE

<b>INPUT/OUTPUT VOLTAGE:</b>	<b>ENVIRONMENTAL:</b>
6-30 VDC	IP66* Rated Enclosure with Encapsulated Electronics
<b>INPUT CURRENT (NOMINAL FOR ALL LINE DRIVER OPTIONS):</b>	<b>SHAFT CURRENT ISOLATION:</b>
80 mA, no load	2500 VRMS ceramic bearings
<b>MAX FULL LOAD CURRENT:</b>	<b>VIBRATION:</b>
187 mA	5-2000 Hz, 20Gs
<b>OUTPUT FORMAT:</b>	<b>SHOCK:</b>
A Quad B with 1/4 AB cycle with A & B high marker (A,/A, B,/B, Z,/Z)	50 Gs, 11 ms
<b>FREQUENCY RANGE:</b>	<b>AXIAL BEARING LOAD:</b>
0 to 250 KHz @6 V & 1 m cable	500 N
<b>PPR:</b>	<b>RADIAL BEARING LOAD:</b>
4 - 10000 standard (for other PPR needs, consult factory)	1200 N
<b>SPEED:</b>	<b>WEIGHT:</b>
6000 RPM Max.**	2.5 lbs. [635 g] approx
<b>TEMPERATURE:</b>	<b>CERTIFICATIONS:</b>
-40° to 85° C	CE, UL Pending
*Requires special ordering code **Max RPM is reduced with PPR>2,500. Consult factory with your application	

## LINE DRIVER TABLE

		LINE DRIVER OPTIONS			
Electrical Specifications		1	2	3	Units
Input Voltage		6-30	6-30	5	VDC
Nom Output Voltage		6-30	5	5	VDC
Voh Typ		Vin-1V	Vin-4.5V	Vin-4.5V	VDC
Vol Typ		0.4V	0.4V	0.4V	VDC
Line Driver		Hx	Hx	Hx	
Output Resistance		75	75	75	ohms
Maximum Peak Current		800	800	800	mA
Maximum Average Current		200	200	200	mA
Cable Drive Capacity		1000 [305]	1000 [305]	1000 [305]	feet [m]
Protection	Reverse Voltage	yes	yes	yes	
	Short Circuit	yes	yes	yes	
	Transient	yes	yes	yes	
	Mis-Wiring	yes	yes	yes	
Alarm	+V out	Output voltage equal to input voltage			
	Alarm	Open collector, normally off, goes low on alarm, sink 100mA max, 50VDC max			
Marker		One per revolution, 1/4 AB Cycle Sync with A & B High			

# SPARE PARTS AND ACCESSORIES

## CABLES

<p><b>B37178 cable offers excellent noise performance, minimized power supply loss and ultra-low capacitance for minimized signal loading.</b></p> <p>The B37178 cable has the following features:</p> <ul style="list-style-type: none"> <li>• -30°C to 80°C temp range</li> <li>• 5 Twisted Pair             <ul style="list-style-type: none"> <li>- 1 Pair 18 AWG</li> <li>- 4 Pair 22 AWG</li> </ul> </li> <li>• Aluminum Mylar Shield &amp; TC Braid Shield</li> </ul>	UL LISTED CABLE ASSEMBLIES		
	1st Connector	2nd Connector	Part Number
	MS 10-Pin	None	CBL1BBA1XPWyyy.y
	MS 10-Pin	M23 12-Pin	CBL1BBA12PWyyy.y
	MS 10-Pin	M12 8-Pin	CBL1BBA1TPWyyy.y
	MS 10-Pin	M12 5-Pin	CBL1BBA15PWyyy.y
	MS 10-Pin	MS 6-Pin	CBL1BBA1EPWyyy.y
	MS 10-Pin	MS 7-Pin	CBL1BBA1JPWyyy.y
	MS 10-Pin	10-Pin Mini TW	CBL1BBA1RPWyyy.y

## TETHER KITS

TETHER CODE	TETHER KIT	BASKET KIT	DESCRIPTION
X	---	B37929-U	NO TETHER
A	B37925-A	B37929-A	FAN COVER 1/4-20
R	B37925-B	B37929-B	FAN COVER 5/16-18
C	B37925-C	B37929-C	FAN COVER 3/8-16
D	B37925-D	B37979-D	FAN COVERS (A+B+C)
E	B37925-E	B37929-E	4.500" C-FACE
F	B37925-F	B37929-F	8.500" C-FACE
M	B37925-M	B37929-M	D+E
U	B37925-U	B37929-U	D+E+F
R	B37925-R	---	BLOCK & PIN

## INSERTS

BORE SIZE CODE	(ITEM 3) SHAFT KIT STYLE U	DESCRIPTION
B	A34966-1	1/2"
C	A34966-2	5/8"
D	A34966-3	3/4"
E	A34966-4	7/8"
P	A34966-5	12mm
Q	A34966-9	14mm
R	A34966-6	15mm
S	A34966-7	16mm
V	A34966-10	19mm
W	A34966-8	20mm

# OUTLINE DRAWINGS

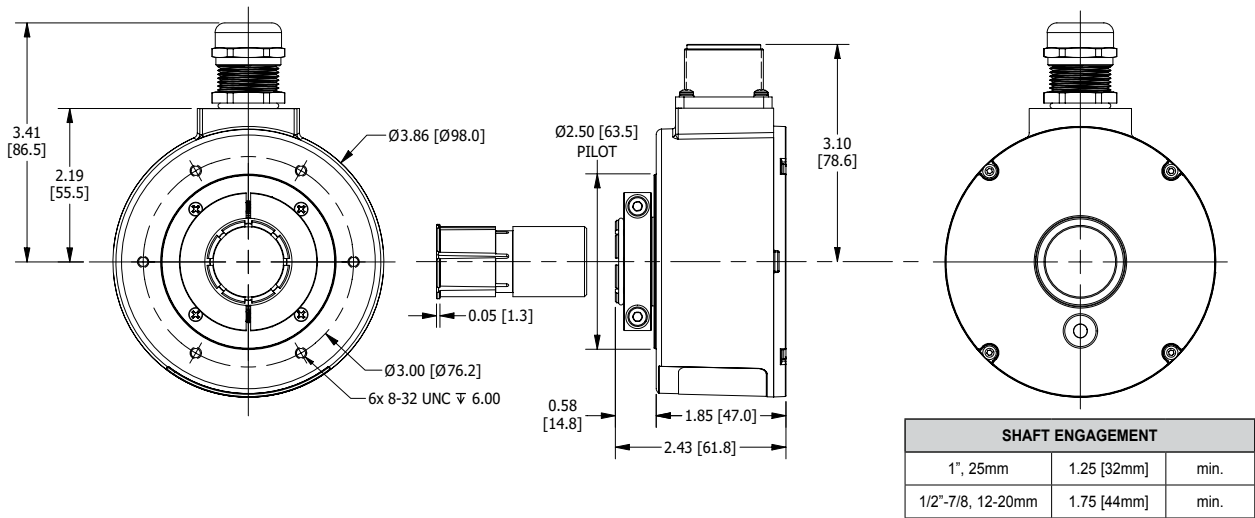

## CONNECTORS

CABLE OPTIONS: W & Y  
(18" STANDARD LENGTH)

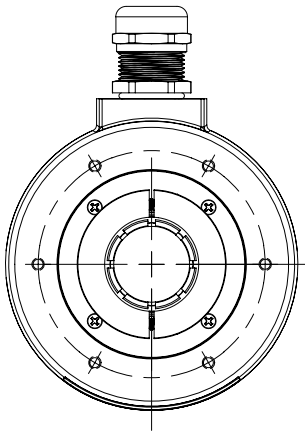

10 PIN MS OPTIONS C & D  
(WITH PLUGS)

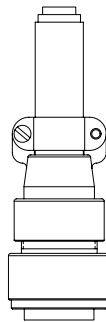

MS OPTIONS A & B  
(W/O PLUGS)

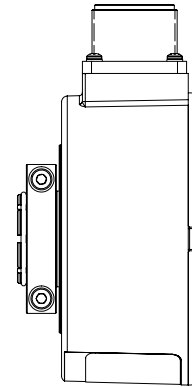

Also available assembled with cable:  
CBL1BBA18PWyyy.y

## TETHERS

OPTION "E"

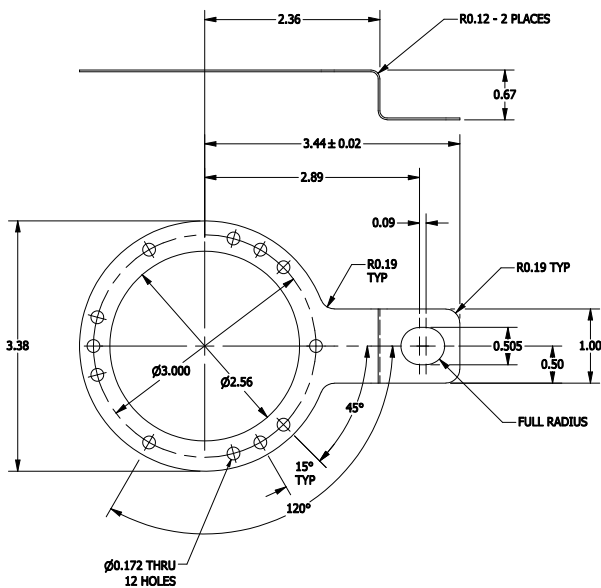

OPTION "F"

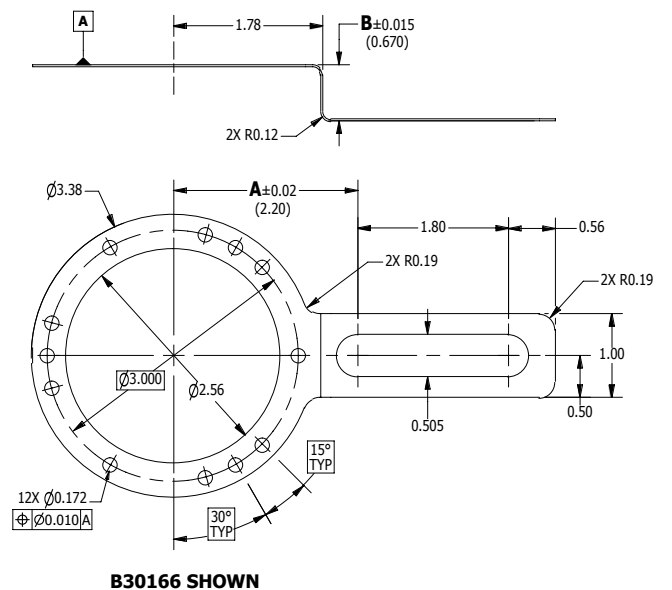

TETHERS CONT'D

OPTION "R"

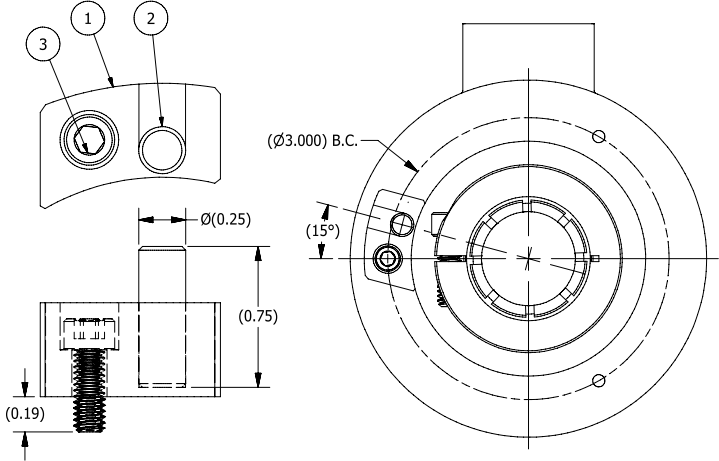



# BASKET INSTALL

**NOTE:**  
Read all instructions before  
Proceeding with installation

- 1) The protective basket guard may be installed over any of the Models listed by the use of "break-out" sections on the guard. Determine which model the guard will be placed over, then using simple hand tools snap out the appropriate section(s). Use a knife or file to remove any sharp edges or flash.

MODEL	SECTION TO BE REMOVED
HS25A	A
HS35A	None
HS35M	B (2 Places)
HS35X	None

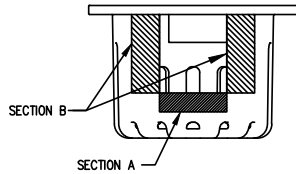

- 2) For installation of the protective guard, encoder tether must be installed as shown in fig. 1. (Fig. 1a is preferred, as it allows the guard to be mounted with 3 bolts. Fig. 1b allows guard to be secured with only 2 bolts).

- 3) After encoder is installed, place the protective basket guard over the encoder with the larger opening over the output termination and the shallow opening over the tether. Ensure the guard is properly sealed on the mounting face and secure with hardware provided. See figs. 2, 3 or 4.

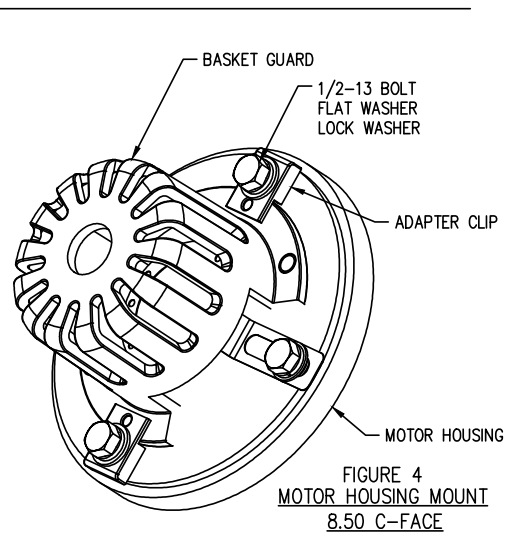
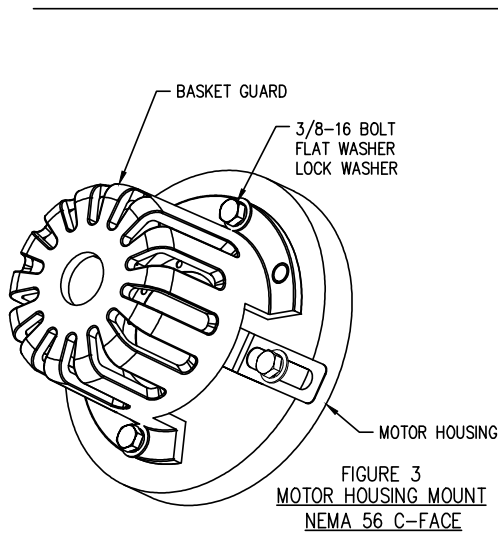
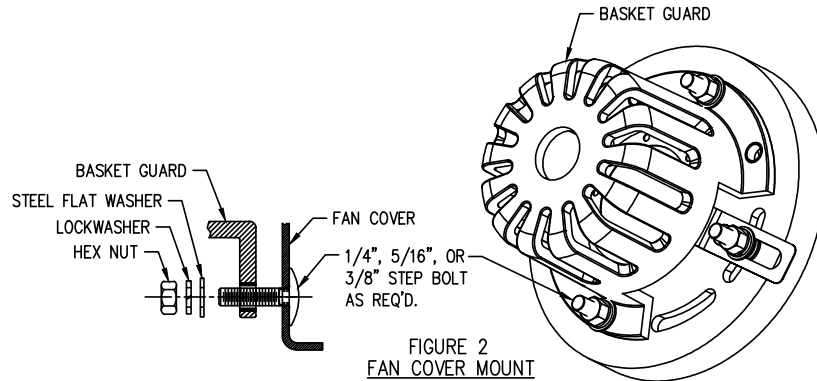

# TETHER INSTALL

**Note:**

**Read all instructions before  
Proceeding with installation**

- 1) Determine tether mounting point. Select a location that Allows the tether to rest in its natural position, so That it is not twisted or stretched.
- 2) Using a phillips screwdriver, mount the tether bracket to The front of the encoder in the position desired using The screws and lockwashers supplied.  
For the hs35m only, do not use threadlocker.  
For installations requiring an accessory guard, the tether And output termination must be positioned as shown in fig. 1 A. For hs25 only, tether may be positioned as shown in fig. 1 B.
- 3) Ensure that the shaft is clean and free of burrs. Loosen the encoder shaft collar. For hs25a and hs35a, apply threadlocker to clamping collar screws. Do not apply threadlocker to HS35M. Slide the encoder onto the shaft until the tether meets the mounting surface or maximum engagement has been reached. Shaft engagement must meet the minimum requirements established in the encoder installation instructions. If tether does not reach the mounting surface, take up extra space using flat washers or spacers. Do not tighten screw on clamping collar.

- 4) Attach free end of tether bracket to a fan cover, motor c-face or machine frame, as required. Use the insulating washers and hardware supplied to secure the tether. See figures 2, 3 or 4. Check to ensure that the tether is in a "no stress" condition, Then firmly tighten clamp collar screw to 35-40 lb-in using T- handle hex wrench. Do not use a right angle hex wrench.
- 5) Customer supplied tethers must allow the encoder to move axially and radially a minimum of  $\pm 0.10$  While preventing rotation. Excess or restricted movement will cause premature bearing failure. It is recommended that insulated hardware be used to electrically isolate the encoder mounting from the machine.

